

Series 2000PV

Mechanical Joint Restraint for PVC Pipe



Distributors:
 Power Plant Supply Co
 Ontario, Canada 416 752 3339
 Atlantic, Canada 902 435 9899
www.powerplantsupplyco.com
info@powerplantsupplyco.com

Series 2012PV on 12inch C900 PVC pipe at a ductile iron fitting.

Features and Applications:

- For restraining plain end PVC pipe at mechanical joint fittings and appurtenances
- Sizes 3 inch through 36 inch
 Sizes 42 inch through 48 inch accommodated by Series 2200
- MEGA-BOND® Restraint Coating System
 For more information on MEGA-BOND, refer to www.ebaa.com
- Constructed of ASTM A536 Ductile Iron
- The mechanical joint follower gland is incorporated into the restraint
- Heavy duty thick wall design
- Support Products Available:
 - Split mechanical Joint style available for 3 inch through 12 inch EBAA Series 2000SV
 - Solid restraint ring harness available for C905 PVC pipe bells EBAA Series 2800
 - Split restraint ring harness available for C900 and C905 PVC pipe bells and PVC fittings EBAA Series 1500, 1600 and 2500
- All 2000PV and related restraint products can be furnished as packaged accessories complete with appropriate restraint, gasket, lubrication and bolting hardware

Nominal Pipe Size	Series Number	Shipping Weight
3	2003PV	7.0
4	2004PV	8.8
6	2006PV	12.1
8	2008PV	16.3
10	2010PV	26.0
12	2012PV	31.4
14	2014PV	47.6
16	2016PV	52.8
18	2018PV	61.8
20	2020PV	70.9
24	2024PV	92.9
30	2030PV	128.5
36	2036PV	161.3
42	2242*	652.0
48	2248*	711.1

*Restraint for pipe size 42 inch and greater, please refer to Series 2200 Brochure found at www.ebaa.com.

U.S. Patent No.
 4627775 4896903 5071175

For use on water or wastewater pipelines subject to hydrostatic pressure and tested in accordance with either AWWA C600 or ASTM D2774.

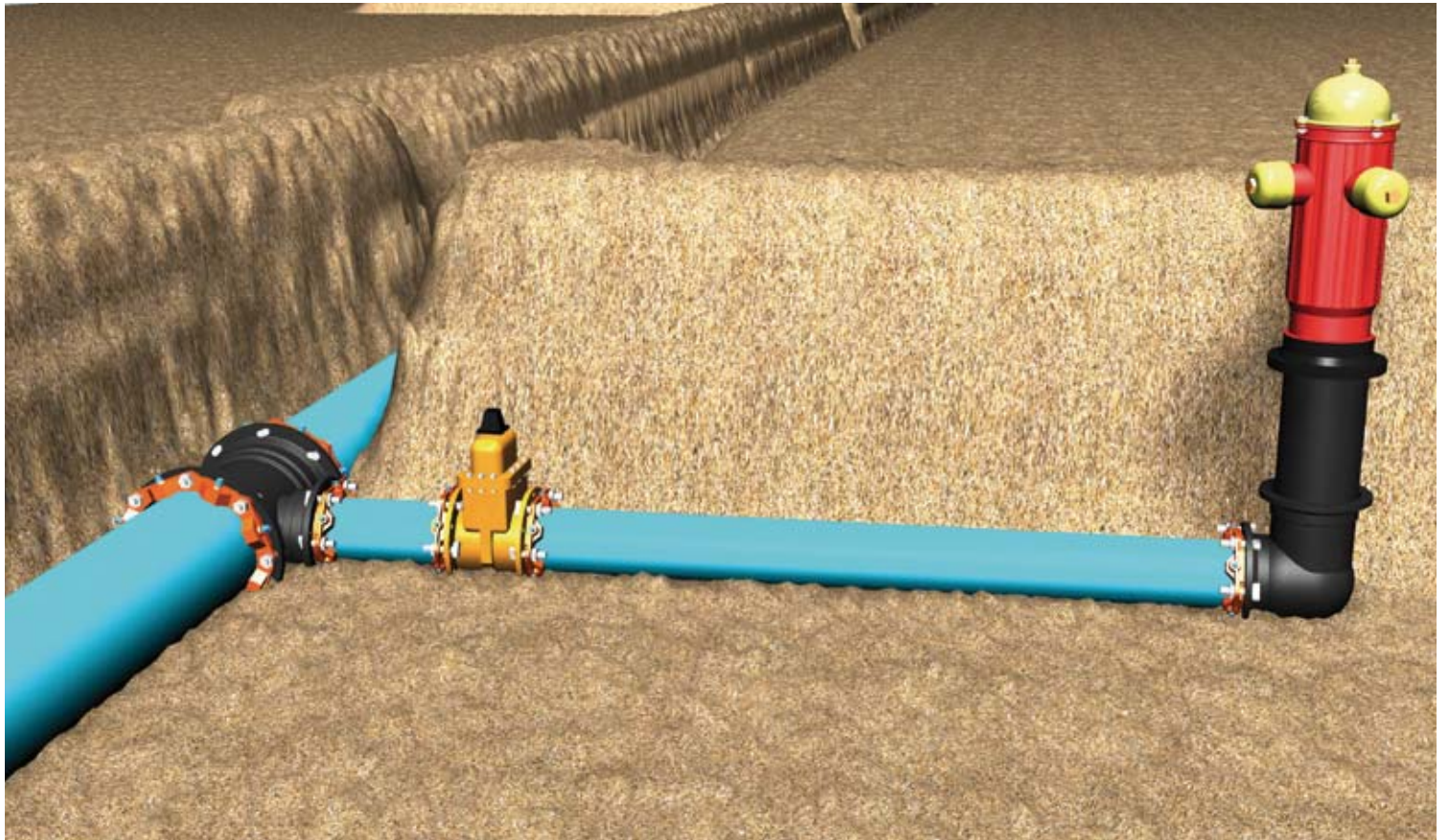

Series 2000PV:

Mechanical Joint Restraint Gland for use With AWWA C900 or IPS Outside Diameter PVC Pipe

The 2000PV MEGALUG Mechanical Joint Restraint is the fastest and most economical method of restraining PVC pipe to mechanical joints. Now the need for costly concrete thrust blocks and corrodible steel tie rods is eliminated. It can be used in straight alignment or at the preset deflection recommended for mechanical joints.

The 2000PV was the first PVC joint restraint to be tested to UNI-B-13, Underwriters Laboratories, and Factory Mutual.

Tested to and meets the requirements of ASTM F 1674-96 'Standard' Test Method for joint restraint products use with PVC pipe through 24 inch size.

UL Listed in the four through twelve inch sizes for joining UL Listed ductile iron fittings to UL Listed, Class 150 PVC pressure pipe. The maximum allowable joint deflection is five degrees.

Factory Mutual approved for use on DR18 PVC pipe in four through twelve inch sizes.



**ASTM
F1674**



The 2000PV MEGALUG Concept

EBAA Iron started manufacturing joint restraint products for PVC pipe in the early 1980s. The testing of early prototypes of various configurations of restraints on large diameter PVC pipe indicated that a restraint device must be capable of consistently and reliably gripping the pipe. If not, the restraint can slip under pressure, resulting in a sudden impact, and cause the pipe to burst. Armed with this background knowledge and an appreciation for the capabilities of PVC pipe, EBAA purposefully deviated from what many in the industry once considered to be the 'only' way to grip PVC pipe. This led to development of the Series

2000PV MEGALUG Mechanical Joint Restraint for PVC pipe.

The design of the 2000PV incorporates the gripping mechanism into the design of the mechanical joint gland and utilizes a simple two part assembly process. The first step involves assembling the joint the same as any standard mechanical joint. The assembly procedure we recommend is that established in AWWA C600. The second is the actuation of the restraint.

Three Testing Methods

The design philosophy behind the 2000PV joint restraint is that the pipe with the restraint should be capable of being tested to the same minimum requirements of the pipe alone. In doing so, the restraint is shown to have no detrimental effect on the pipe and will have the same pressure rating and safety factor as the pipe on which it is used. To that end the 2000PV has been subjected to hundreds of static and cyclic pressure tests to demonstrate the performance and reliability of the restraint.

One of the primary tests of PVC is its quick burst strength. For pipe meeting the requirements of AWWA C900, AWWA C905 and ASTM 2241, the minimum quick burst requirement for the hoop stress is 6,400 PSI. For DR18, pipe pressure is 755 PSI.

The second test is sustained pressure test at a hoop stress of 4,200 PSI. For DR18 pipe, that pressure is 500 PSI.

Third, a conservative cyclic pressure surge design for the pipe exists in the form of Vinson Equation.

The 2000PV restraint has been tested to over one million cycles to the peak pressures predicted by the Vinson Equation for that number of cycles.



Series 2000PV Takes the Load

On April 11, 1997 EBAA Iron performed a remarkable force demonstration of their Series 2000PV joint restraint. With the use of EBAA's Series 2000PV using standard mechanical joint installation on 12 inch PVC pipe, and a 80 Ton Motor Crane, EBAA Iron lifted a D7 Caterpillar Track Type Tractor weighing in at 50,350 lbs. Along with this, the Series 2000PV has been tested to over 700 PSI. Concluding that EBAA's Series 2000PV MEGALUG can take the load.

Mechanical Joint Restraint for AWWA PVC Pipe Sample Specification

(The text of the specification below can be downloaded as a Microsoft® Word Doc from our website www.ebaa.com)

Restraint devices for mechanical joint fittings and appurtenances conforming to either ANSI/AWWA C111/A21.11 or ANSI/AWWA C153/A2153, shall conform to the follow:

Design

Restraint devices for nominal pipe sizes 3 inch through 36 inch shall consist of multiple gripping wedges incorporated into a follower gland meeting the applicable requirements of ANSI/AWWA C110/A21.10.

The devices shall have a working pressure rating equal to that of the pipe on which it is used. Ratings are for water pressure and must include a minimum safety factor of 2:1 in all sizes.

Material

Gland body, wedges and wedge actuating components shall be cast from grade 65-45-12 ductile iron material in accordance with ASTM A536.

Ductile iron gripping wedges shall be heat treated within a range of 370 to 470 BHN.

Three (3) test bars shall be incrementally poured per production shift as per Underwriter's Laboratory (U.L.)

Specifications and ASTM A536. Testing for tensile, yield and elongation shall be done in accordance with ASTM E8.

Chemical and nodularity tests shall be performed as recommended by the Ductile Iron Society, on a per ladle basis.

Traceability

An identification number consisting of year, day, plant and shift (YYDDD) (plant designation) (Shift number), shall be cast into each gland body.

All physical and chemical test results shall be recorded such that they can be accessed via the identification

number on the casting. These Material Traceability Records (MTR's) are to be made available, in hard copy, to the purchaser that requests such documentation and submits his gland body identification number.

Production pieces that are too small to accommodate individual numbering, such as fasteners and wedges, shall be controlled in segregate inventory until such time as all quality control tests are passed. These component parts may then be released to a general inventory for final assembly and packaging. All components shall be manufactured and assembled in the United States. The purchaser shall, with reasonable notice, have the right to plant visitation at his/her expense.

Installation

Mechanical joint restraint shall require conventional tools and installation procedures per AWWA C600, while retaining full mechanical joint deflection during assembly.

Proper actuation of the gripping wedges shall be ensured with torque limiting twist off nuts.

Approvals

Mechanical Joint Restraints shall be Listed by Underwriters Laboratories in the 4 inch through 12 inch sizes.

Mechanical Joint Restraints shall be Factory Mutual Approved in the 4 inch through 12 inch sizes.

Mechanical Joint Restraints, 4 inch through 24 inch, shall meet or exceed

the requirements of ASTM F1674 of the latest revision.

Mechanical joint restraint shall be Series 2000PV produced by EBAA Iron Inc. or approved equal.

MEGA-BOND® Restraint Coating System

All wedge assemblies and related parts shall be processed through a phosphate wash, rinse and drying operation prior to coating application. The coating shall consist of a minimum of two coats of liquid thermoset epoxy coating with heat cure to follow each coat.

All casting bodies shall be surface pretreated with a phosphate wash, rinse and sealer before drying. The coating shall be electrostatically applied and heat cured. The coating shall be a polyester based powder to provide corrosion, impact and UV resistance.

The coating system shall be MEGA-BOND by EBAA Iron, Inc. or approved equal. Requests for approved equal must submit coating material and process details for review prior to bid.

For more information regarding MEGA-BOND, refer to the MEGA-BOND brochure or visit www.ebaa.com.

Support Products

for more information concerning these products, please consult the catalog or www.ebaa.com

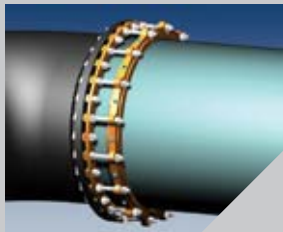

Series 2200

MEGALUG® Restraint for C905 PVC Pipe at Mechanical Joint Fittings
Sizes 42 and 48 inch

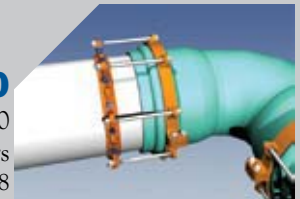

Series 2500

MEGALUG® Restraint for C900 and C905 PVC Pipe at PVC Fittings
Sizes 4 inch through 48



Series 2800

MEGALUG® Restraint Harness for C905 PVC Pipe
Sizes 14 inch through 48
Sizes 4 through 12 accommodated by either Series 1500 or 1600

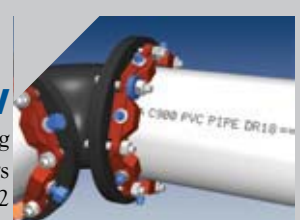

Series 2000SV

Split MEGALUG® Restraint for existing C900 PVC Pipe at Ductile Iron Fittings
Sizes 4 inch through 12

Series 2000PV Submittal Reference Drawing

EBAA IRON

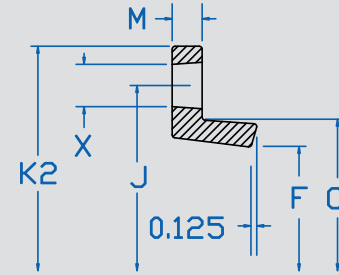
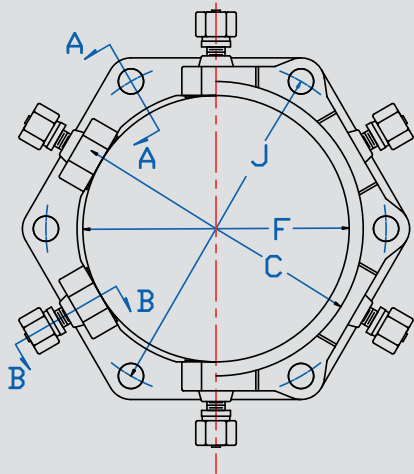

SECTION A-A

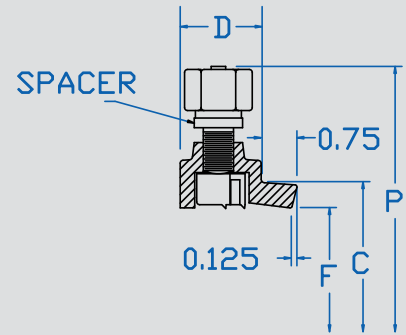

SECTION B-B

MADE IN USA

Nominal Pipe Size	Series Number	C	D	F	M	P	P*	X	J	K2	Wedge Qty	Bolt Qty	Weight (lbs.)
3	2003PV	4.84	1.55	3.60	0.50	9.8	8.6	3/4	6.19	7.69	4	4	7.0
4	2004PV	5.92	1.68	4.90	0.50	10.5	9.5	7/8	7.50	9.13	4	4	8.8
6	2006PV	8.02	1.68	7.00	0.50	13.0	12.1	7/8	9.50	11.13	6	6	12.1
8	2008PV	10.17	1.68	9.15	0.62	14.5	13.6	7/8	11.75	13.38	6	6	16.3
10	2010PV	12.22	2.10	11.20	0.62	17.0	16.0	7/8	14.00	15.63	8	8	26.0
12	2012PV	14.32	2.10	13.30	0.75	19.0	18.1	7/8	16.25	17.88	8	8	31.4
14	2014PV	16.40	2.25	15.49	0.88	21.7	20.9	7/8	18.75	20.38	10	10	47.6
16	2016PV	18.50	2.25	17.58	0.88	23.8	23.0	7/8	21.00	22.63	12	12	52.8
18	2018PV	20.60	2.25	19.68	1.13	25.9	25.1	7/8	23.25	24.88	12	12	61.8
20	2020PV	22.70	2.25	21.79	1.25	28.0	27.2	7/8	25.50	27.13	14	14	70.9
24	2024PV	26.90	2.75	25.99	1.42	32.3	31.5	7/8	30.00	31.63	16	16	92.9
30	2030PV	33.29	2.70	32.22	1.50	38.5	37.7	1 1/8	36.88	39.12	20	20	128.5
36	2036PV	39.59	2.70	38.52	1.50	44.8	44.0	1 1/8	43.75	46.00	24	24	161.3
42	2242	Submittal information for pipe sizes 42 inch and greater can be found in the Series 2200 Brochure.											
48	2248	Submittal information for pipe sizes 42 inch and greater can be found in the Series 2200 Brochure.											

NOTE: Dimensions are in inches and are subject to change without notice.
For applications or pressures other than those shown, please contact EBAA for assistance.

Nominal Pipe Size	Series Number	Ratings for Ordinary Water Works w/Transient surges only						Ratings for Peak Pressures used in Sewage Force Mains and other installations designed for Cyclic Surges of 1-Mill. Cycles						C905 PVC Pipe			
		DR14	DR18	DR25	SDR17	SDR21	SDR26	DR14	DR18	DR25	SDR17	SDR21	SDR26	DR18	DR25	DR32.5	DR41
3	2003PV	200	150	100	250	200	160	200	150	100	200	160	120	-	-	-	-
4	2004PV	200	150	100	250	200	160	200	150	100	200	160	120	-	-	-	-
6	2006PV	200	150	100	250	200	160	200	150	100	200	160	120	-	-	-	-
8	2008PV	200	150	100	250	200	160	200	150	100	200	160	120	-	-	-	-
10	2010PV	200	150	100	250	200	160	200	150	100	200	160	120	-	-	-	-
12	2012PV	200	150	100	250	200	160	200	150	100	200	160	120	-	-	-	-
14	2014PV	-	-	-	-	-	-	-	-	-	-	-	-	235	165	125	80
16	2016PV	-	-	-	-	-	-	-	-	-	-	-	-	235	165	125	100
18	2018PV	-	-	-	-	-	-	-	-	-	-	-	-	200	165	-	-
20	2020PV	-	-	-	-	-	-	-	-	-	-	-	-	200	165	-	-
24	2024PV	-	-	-	-	-	-	-	-	-	-	-	-	165	165	125	100
30	2030PV	-	-	-	-	-	-	-	-	-	-	-	-	-	165	125	100*
36	2036PV	-	-	-	-	-	-	-	-	-	-	-	-	-	125	125	100*

* Refer to Series 2200 to achieve rated pressure on DR41 in stated pipe size.

Spacer Instructions

Ductile Iron or C900 PVC Pipe Sizes

For installation on C900 PVC pipe, use as received and install per instructions.

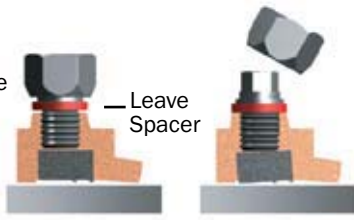

ASTM 2241 PVC Pipe Sizes (IPS O.D.)

For installation on ASTM 2241 sized pipe, remove spacers and replace screws. Install per instructions.

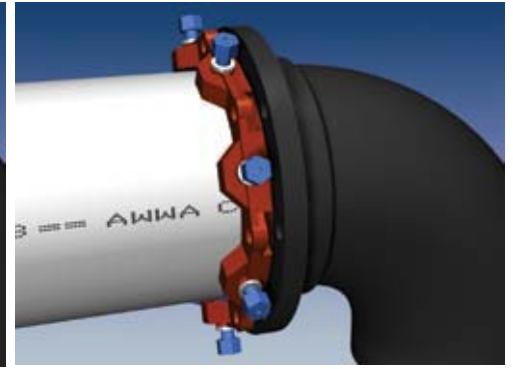
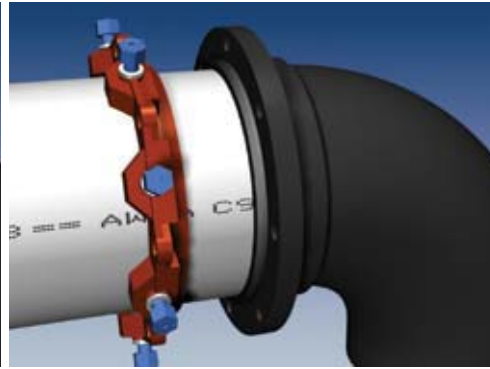
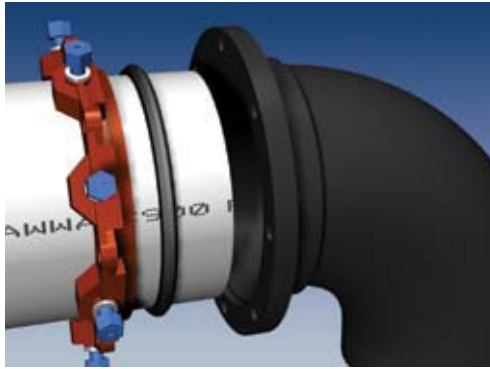
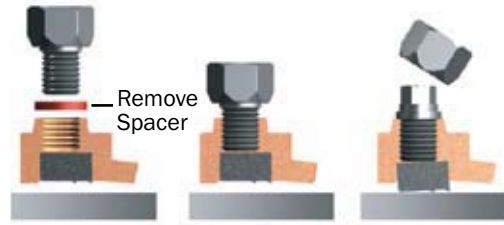

1. Identify the pipe. The 2000PV is for use with PVC and HDPE pipe. The 4 inch through 12 inch size may be used on C900, IPS, and C909 PVC pipe as well as C906 HDPE pipe. Check to see if the spacers under the screws are in place. If the pipe is C900 or is ductile iron O.D., proceed with spacers in place. If the pipe is IPS O.D., remove the spacers. Since 3 inch and 14 inch through 24 inch restraints are only used with one pipe diameter, no spacers are used.
2. Clean the socket and the plain end. Lubrication and additional cleaning should be provided by brushing both the gasket and plain end with soapy water or an approved pipe lubricate meeting the requirements of ANSI/AWWA C111/A12.11 just prior to slipping the gasket onto the plain end for joint assembly. Place the gland on the plain end with the lip extension toward the plain end; follow by the gasket with the narrow edge of the gasket toward the plain end [The gasket provided may have been the EBAA-Seal™ Improved Mechanical Joint Gasket. This gasket is bi-directional and has no front or back. The use of a pipe wall stiffening insert is required on High Density Polyethylene pipe.].
3. Insert the pipe into the socket and press the gasket firmly and evenly into the gasket recess. Keep the joint straight during assembly.
4. Push the gland toward the socket and center it around the pipe with the gland lip against the gasket. Insert bolts and hand-tighten nuts. Make deflection after joint assembly but before tightening bolts.

NOTE: In cold weather it is preferable to warm the gasket to facilitate assembly of the joint.

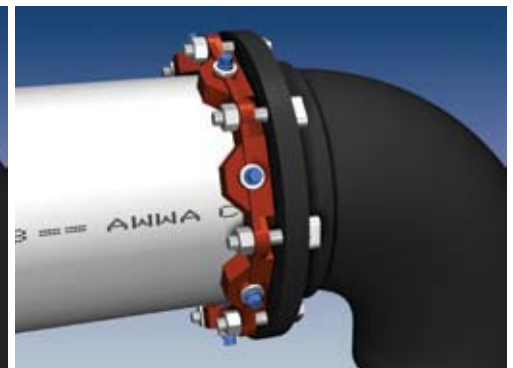

5. Tighten the bolts to the normal range of bolt torque [45-60 ft-lbs for 3 inch, 75-90 ft-lbs for 4 inch through 24 inch, 100-120 ft-lbs for 30 inch and 36 inch, and 120-150 ft-lbs for 42 inch and 48 inch.] while at all times maintaining approximately the same distance between the gland and the face of the flange at all points around the socket. This can be accomplished by partially tightening the bottom bolt first, then the top bolt, next the bolts at either side, finally the remaining bolts. Repeat the process until all bolts are within the appropriate range of torque. In large sizes (30-48 inch), five or more repetitions may be required. The use of a torque-indicating wrench will facilitate the procedure.
6. Tighten the torque limiting twist-off nuts in a clockwise direction (direction indicated by arrow on top of nut) until all wedges are in firm contact with the pipe surface. Continue tightening in an alternating manner until all of the nuts have been twisted off.
7. If removal is necessary, utilize the 5/8 inch hex heads provided. If reassembly is required, assemble the joint in the same manner as above; tighten the screws to 60 to 80 ft-lbs. If the Series 2000PV restraint is removed from the pipe, be sure that all of the screws, spacers (if required), and wedges are in place before the restraint is reassembled.

*These steps are requirements of AWWA C600.

Distributors:
Power Plant Supply Co
Ontario, Canada 416 752 3339
Atlantic, Canada 902 435 9899
www.powerplantsupplyco.com
info@powerplantsupplyco.com

